

AKM 115SA: Smart Actuator for ball valve

How energy efficiency is improved

Ball valve actuator with integrated, freely programmable controller and cloud connection in one device. Can be integrated into a local building automation system via BACnet or into the SAUTER Cloud via MQTT. Communicates via WLAN and Bluetooth. Automatic adaptation to the ball valve, precise activation and high energy efficiency with minimal operating noise and smart functions



AKM115SAF232

Features

- Smart Actuator as an intelligent IoT solution for autonomous control of heating and air-conditioning applications in smart buildings
- Ready-made HVAC standard applications enable efficient installation and commissioning of small systems
- Applications are selected from the library via smartphone app and installed on the Smart Actuator
- BACnet, Bluetooth LE and WLAN interface for flexible system integration
- Commissioning, parameterisation and remote access to the system are conveniently carried out via a smartphone app
- As an IoT device, the cloud connection for remote access takes place via MQTT using TLS encryption
- Extensive diagnostic data from the actuator enables predictive maintenance of installations
- Enables creation of Smart Actuator networks with distributed intelligence
- Optionally, the Smart Actuator can be used flexibly in BA networks due to free programmability via CASE Suite
- Real-time clock for calendar functions and time programmes
- Two universal I/Os for connecting external sensors and actuators
- Direct connection of a room operating unit
- Flexibly expandable with up to two Smart Actuator SAIO 100 I/O modules for comprehensive control tasks
- Pre-assembled cables, with colour- and mechanically-coded connectors, allow fast and error-free wiring
- Fitting without tools using a bayonet ring made of glass-fibre reinforced plastic
- BLDC motor technology enables extensive diagnostic functions
- Intelligent angle of rotation adaptation and detection incl. feedback signal
- Electronic, torque-dependent cut-off
- Gear unit can be disengaged for manual adjustment
- For operating the 2- and 3-way ball valves VKR, VKRA, BKR, BKRA, VKAI, VKAA, BKLI, BKTI and BKTA, as well as 6-way ball valve B2KL

Technical data

Power supply		
Power supply		24 VAC, -10%/+20%, 50...60 Hz 24 VDC, -10%/+20%
Parameters		
Surge-voltage resistance		500 V (EN 60730)
Rotational torque		8 Nm
Holding torque ¹⁾		8 Nm
Angle of rotation		90°
Response time		200 ms
Running time for 90°		35/60/120 sec.
Characteristic		Linear, (inverse) equal percentage, (inverse) quadratic, free characteristic
Operating noise (unloaded)		< 30 dB (A)
Ambient conditions		
Media temperature ²⁾		Max. 100 °C
Ambient temperature		-10...55 °C

¹⁾ Holding torque energised and de-energised

²⁾ At media temperatures < 5 °C or > 100 °C, appropriate accessory must be used



Ambient humidity	5...85% rh, no condensation
Storage and transport temperature	-20...70 °C

Inputs/outputs		
	Number of universal I/O	2
Type of inputs	Analogue input U	0...10 V (R _i = 100 kΩ, ±0.05 V)
	Analogue input I	4...20 mA (with ext. resistor 500 Ω or accessory 053060311**)
	Digital input ³⁾	Closed: ≤ 1 VDC, 1 mA Open: ≥ 4 VDC
	Ni1000	-20...100 °C (DIN 43760)
	Pt1000	-20...100 °C (IEC 751)
	Resistance	200...3000 Ω
Type of output	Analogue output U	0...10 V (±0.1 V)

Function		
	BACnet data point objects	Max. 50
	BACnet client links	16
	Control	6 loops
	Active COV subscription	64
Dynamic objects	Time programmes	4 (Schedule)
	Calendar	3 (Calendar)

Architecture		
	Processor	ARM Cortex-M7 (528 Mhz)
	RAM (memory)	1024 kB
	Flash	2 × 16 MB external, for data and system
	Flash encryption	128 bit AES
	Application data	Via CASE Engine or mobile app
	Operating system	Zephyr
	Cycle time	100 ms
	Mobile app	For commissioning and maintenance
	Cloud	Via MQTT to IoT Hub
	Real-time clock	For time programmes and calendars

Interfaces, communication		
RS-485 A connection ⁴⁾	Communication protocol	BACnet MS/TP, ¼ load
	Connection	2 × 3-pin connector, coded, Daisy Chain
	Termination/Pull-Up/Pull-Down	Internal, switchable via software
RS-485 B connection ⁵⁾	Communication protocol	SLC master
	Use	2 × I/O module, 1 × ecoUnit
	Connection	5-pin connector, coded
Bluetooth	Termination	Internal, switchable via software
	Version	BLE 4.2
	Range	< 10 m
WLAN	Radiation	4 mW
	Standard	IEEE 802.11 b/g
Indicator/display	LED indicator	2 status LEDs (green/red and blue)

Construction		
	Fitting position	Connections at the bottom or side, not at the top
	Dimensions W × H × D	168 × 137 × 74 mm
	Weight	0.7 kg
	Housing	Lower section black, upper section yellow
	Housing material	Flame retardant plastic, PC/ABS

³⁾ Switching thresholds: 2.28 V (0 to 1) and 2.69 V (1 to 0) or 2.19 kΩ (0 to 1) and 2.69 kΩ (1 to 0)

⁴⁾ Not electrically isolated

⁵⁾ Not electrically isolated

Standards, directives		
	Type of protection	IP54 (EN 60529)
	Protection class	III (IEC 60730)
	Environment class	3K3 (IEC 60721)
CE conformity according to UKCA conformity according to	RED Directive 2014/53/EU	EN 60730-1:2011
	Radio Equipment Regulations 2017 (UK)	EN 60730-2-14:1997 + A1:2001, A11:2005; A2:2008 EN 62479:2010 EN 301 489-1 V1.9.2 EN 61000-6-2:2005; AC:2005 EN 61000-6-3:2007 + A1:2011; AC 2012 EN 300 328 V2.2.2
	RoHS Directive 2011/65/EU & 2015/863/EU	EN IEC 63000: 2018
	Regulations: restriction of hazardous substances (RoHS UK)	

Overview of types		
Type	Features	Power consumption
AKM115SAF232	Smart Actuator for ball valve, RS-485	Max. 5 W / 10 VA (without peripherals)

 *Power consumption: Without connected peripheral devices (room operating units, sensors, actuators or I/O modules)*

Accessories	
Type	Description
0510420001	Adaptor required when temperature of the medium > 100 °C
0510240011	Adaptor required when temperature of the medium < 5 °C
SAIO100F020	I/O module, 5 × UI/AO, 3 × relay
05393601000	Dummy plug spare part set IP54
EY-PS021F011	Power supply module 85...264 VAC / 24 VDC, 1 A; 3 HP DIN rail mounting
EY-PS021F021	Power supply module 85...264 VAC / 24 VDC, 2 A; 4 HP DIN rail mounting
EY-PS021F041	Power supply module 85...264 VAC / 24 VDC, 4 A; 5 HP DIN rail mounting

 *For power cables or connecting cables (053060****), see order code in PDS 53.950*

Description of operation

The AKM 115SA Smart Actuator is an integrated combination of a freely programmable automation station (AS) and a ball valve actuator. Without additional controllers, it enables self-sufficient, energy-optimised control to be set up in primary systems or individual rooms. Together with an ecoUnit room operating unit and up to two additional SAIO 100 I/O modules, even complex HVAC systems or room controls can be implemented.

For system integration and programming, the Smart Actuator can be accessed via the communication interfaces Bluetooth LE, WLAN and RS485 with BACnet MS/TP.

The application programming is performed with SAUTER CASE Suite. Finished applications can be stored in the SAUTER Cloud and loaded onto the Smart Actuator from there. Commissioning, access to application visualisation, and documentation are carried out using SAUTER CASE Suite tools via a mobile app or via the web interface in the SAUTER Cloud. As an IoT device, the Smart Actuator connects to the SAUTER Cloud IoT hub via the integrated WLAN interface. The data transmission, encrypted using TLS, is performed via the MQTT protocol. The Smart Actuator can be integrated into a building automation network via BACnet MS/TP as an application-specific controller (B-ASC).

The Smart Actuator can be combined with 2-, 3- and 6-way ball valves. It is fitted without force by means of a bayonet connector. Manual adjustment is performed by disengaging the gears (push button on the actuator housing) and turning the lever. When the push button is released, the actuator moves to the current position setpoint. The actuator position is measured via the electromechanical travel measurement system and can be read out via the available interfaces. An additional adaptation run is not necessary after a manual adjustment or a power failure.

The brushless motor, inductive travel measurement system and electronics concept ensures parallel operation of multiple ball valve actuators of the Smart Actuator and SUT (SAUTER Universal Technology) valve actuator types.

Intended use

The Smart Actuator is only suitable for the purpose intended by the manufacturer, as described in the "Description of operation" section. All related product regulations must also be adhered to. Modifying or converting the product is not admissible.

The device is only allowed to be used in HVAC building systems for control and regulation purposes. Other uses require the prior consent of the manufacturer.

Improper use

The Smart Actuator is not suitable for:

- Safety applications
- Machine applications
- Transport applications and at altitudes above 2000 metres
- Outside applications and in rooms with the risk of condensation

Engineering notes

Power supply of the Smart Actuator

The Smart Actuator is supplied with 24 VAC or 24 VDC via the supplied 24 V connection cable.

A Y-cable (05306020201) is available for daisy-chaining the power supply. Depending on the number of connected actuators and further sensors or activators, the voltage drop over the selected cable length must be taken into account.

Smart Actuator without peripherals

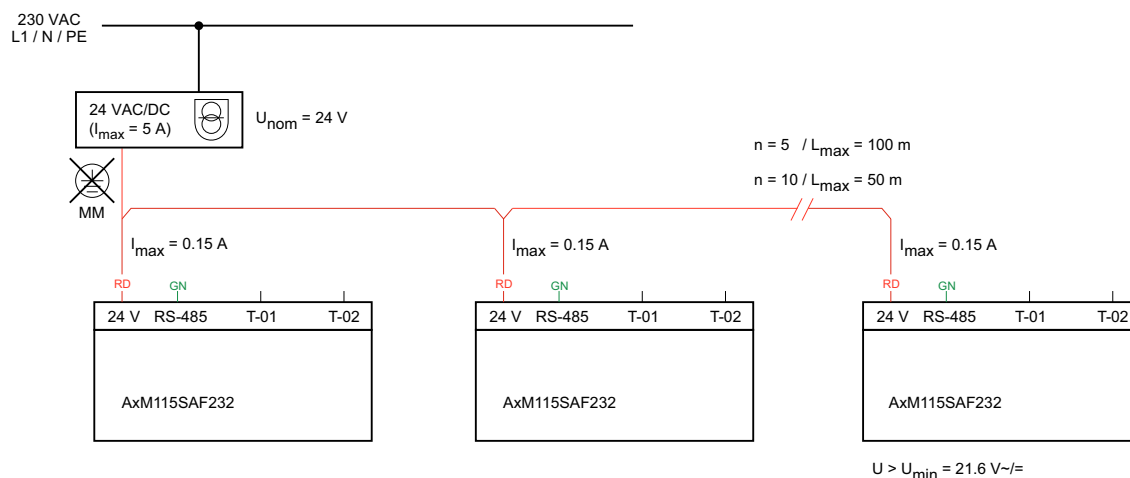

💡 n : Number of units

💡 L : Line length

Notice



For the greatest possible system stability, it is recommended to supply the entire system with DC voltage. When operating with AC voltage, the power supply must be designed with a power reserve of 20%.

When connecting external devices via the Smart Actuator, the maximum current consumption increases up to $I_{\max} = 0.5 \text{ A}$ per Smart Actuator. The maximum length of the 24 V supply cable is thus reduced by half for the same number of devices.

Smart Actuator with connected field devices

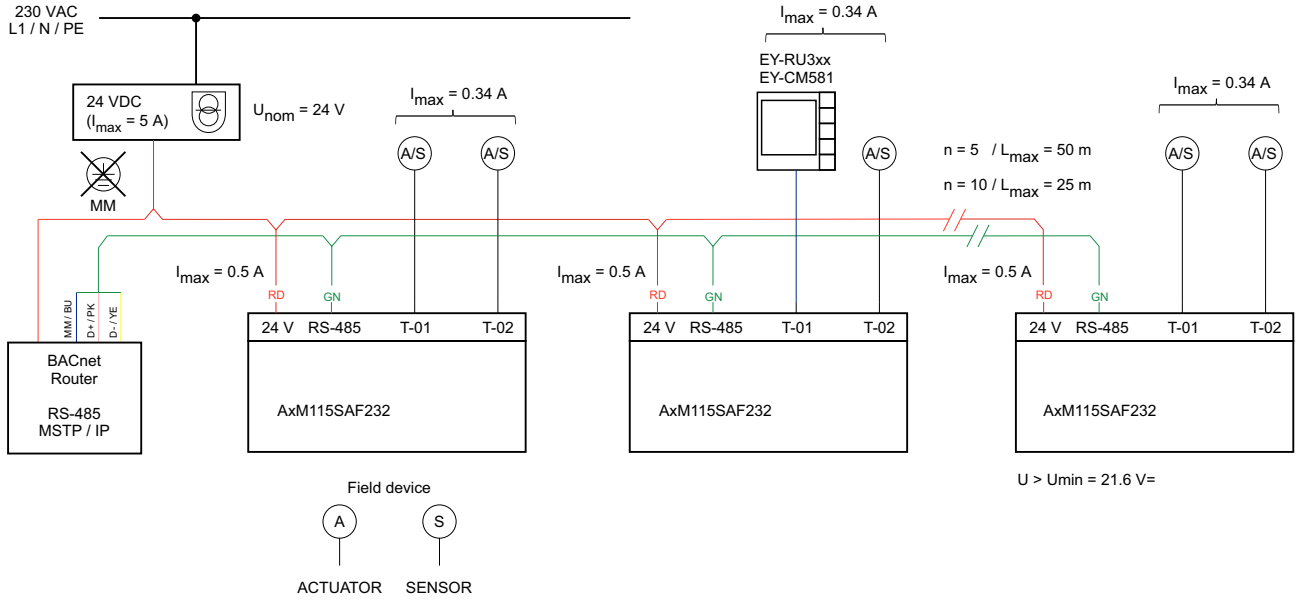

Notice



If no standard cable (053060200xx) is used, it must be ensured that the cross-section of the power cable is adapted to the required power and length. The conductor cross-section should not be less than 0.75 mm².

Power supply of SAIO 100 I/O module, ecoUnit355 and field devices via the Smart Actuator

Active sensors, actuators, an SAIO 100 I/O module or an ecoUnit3**/ecosCom581 room operating unit can be supplied with voltage via the Terminal 1 (T-01) and Terminal 2 (T-02) connections. The voltage provided via the terminals depends on the supply voltage of the Smart Actuator. When the Smart Actuator is supplied with 24 VAC, AC voltage is present at the terminals; when supplied with 24 VDC, DC voltage is present. In total, up to 340 mA current can be provided for external devices via the actuator.

Depending on the input voltage at the Smart Actuator, the following connection configurations are supported at Terminal 1:

Smart Actuator	SAIO 100 I/O module at T-01	ecoUnit3**/ecosCom581 at T-01
24 VAC	Yes	No
24 VAC	Yes	Yes, if connection is made via SAIO 100 I/O module T-01
24 VDC	Yes	Yes

Connection of IO module and room operating unit without separate power supply

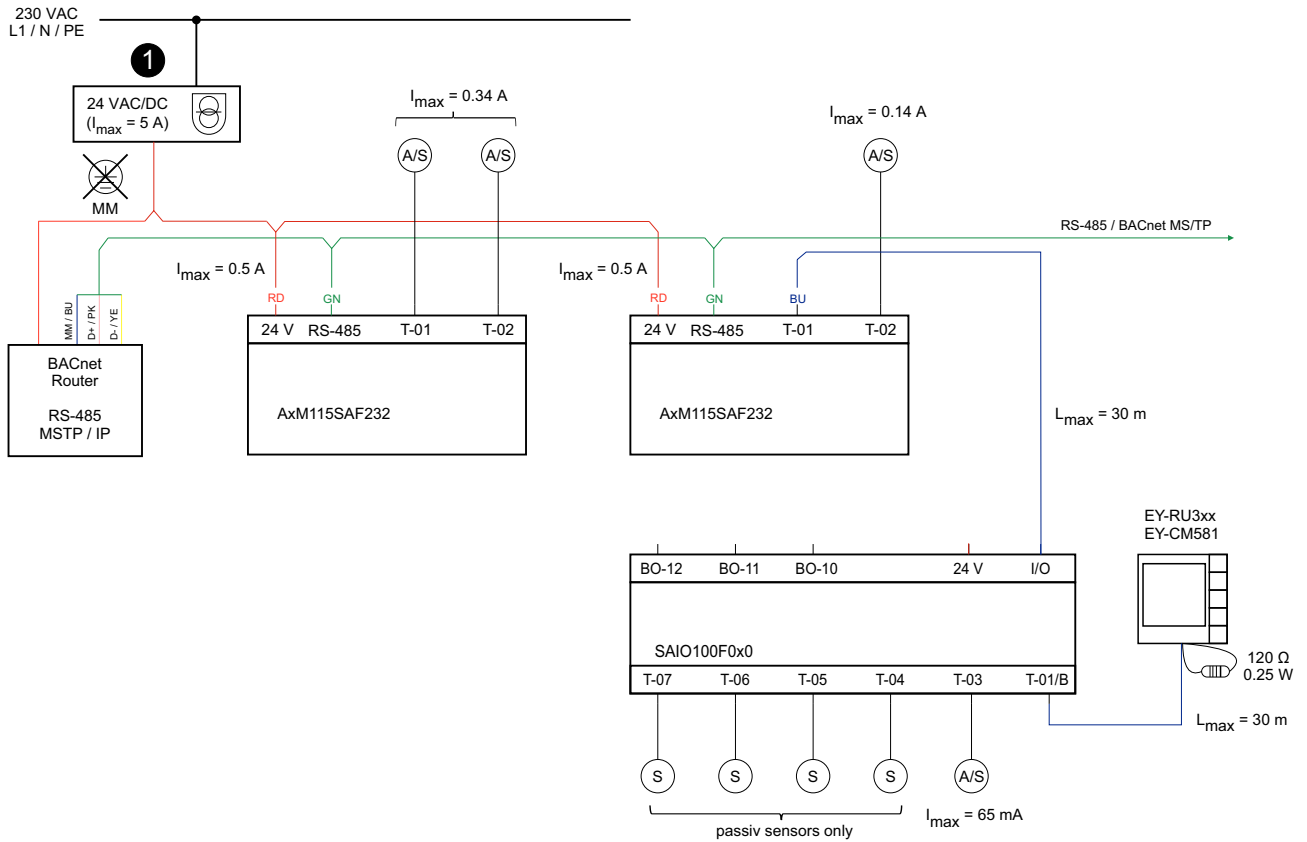

(1) Supply with DC voltage preferred

Notice



- Terminal T-02 may be loaded with a maximum of 140 mA if an I/O module is connected to T-01.
- If terminals T-01 and T-02 are loaded with more than 340 mA, the internal thermal fuse switches off the terminals. The thermal fuse can be reset by disconnecting the terminals for 30 sec.
- When operating the I/O module without a separate power supply, terminals T-04 to T-07 on the I/O module can only be operated with passive sensors. It is recommended to operate the I/O module with an additional external supply.
- Connect devices with a 2-way rectifier only together with a DC voltage supply.

When connecting two SAIO 100 I/O modules to the Smart Actuator, the I/O modules must be supplied externally.

Smart Actuator with two I/O modules and one room operating unit

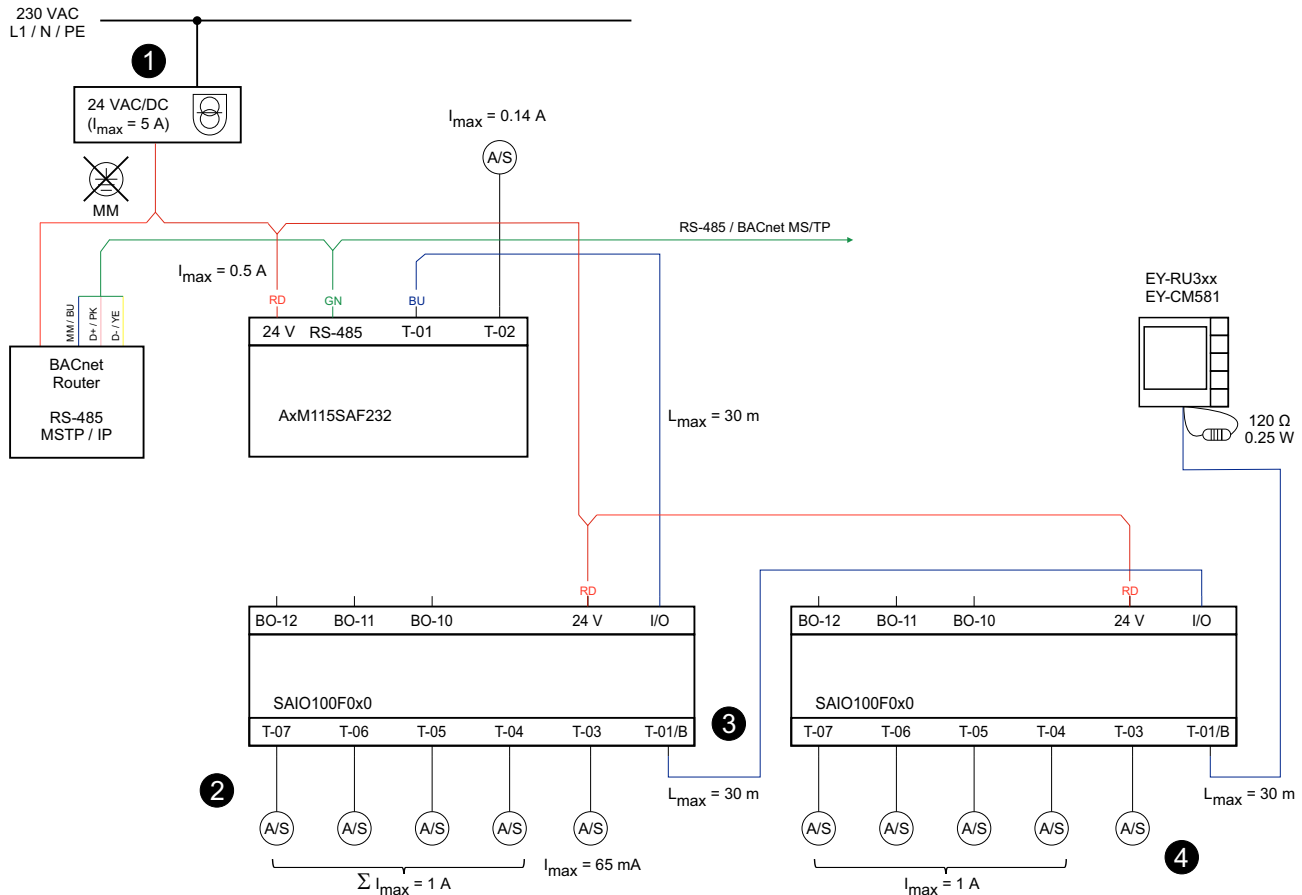

- (1) Supply with DC voltage preferred
- (2) Max. 100 mA per terminal with 30 metre cable length
- (3) When using a second I/O module, set the DIP switch on the first I/O module to 5 V and supply the second I/O module separately with voltage
- (4) Only a passive sensor can be connected to T-03 of the second I/O module

When routing analogue signals such as inputs / outputs (0...10 V) with simultaneous 24 V voltage supply via the Smart Actuator or an I/O module, the current loading should not exceed 100 mA per terminal for a cable length of 30 metres in order to avoid measurement deviations. When Smart Actuator cables up to 30 metres long are used, the measurement error remains below 1%. If higher currents are required, a separate supply or shorter cable lengths must be planned.

Example

Connection and supply of the AVM215SF132R valve actuator (via the Smart Actuator)

- Power consumption of AVM215SF125R: max. 3.5 W
- Current consumption: max. 0.145 A
- Cable length: max. 20 m

For peripheral devices that cannot be supplied by the 24 V voltage of the Smart Actuator or the SAIO 100 I/O module, e.g. because the device requires a different voltage or the power consumption is too high, the power supply can be used directly from the voltage source. In this case, the peripheral device and the Smart Actuator must be connected to the same ground. The brown conductor of the

Smart Actuator IO cable (3-core for T-02, 5-core for T-01) must not be connected in this case and must be insulated.

**NOTICE!**

- ▶ When supplying power to peripheral devices separately, the circuits must be electrically isolated from each other.
- ▶ Wire the devices properly. Avoid earth or ground loops.
- ▶ Avoid parallel, bundled routing of sensor or actuator lines or bus lines and cables carrying high currents.

Fitting

**Notice**

- Only qualified electricians are permitted to fit and connect the products.
- Prevent access by laypersons.
- Disconnect defective or damaged devices from the power supply and replace them immediately.

The Smart Actuator is fitted directly on the ball valve in the system. It is fitted by inserting and turning the bayonet ring until the limit stop without any additional adjustment. No tools are required. The spindle of the ball valve is automatically coupled with the driver stem either by manual adjustment or by applying an actuating signal to move the actuator to the required position.

**Notice**

- After manual adjustment via the release button, let this go again and, if necessary, move the manual adjustment lever until the gears engage.
- Secure the device so that it cannot fall down. Otherwise, the actuator must be secured using additional measures.

Removal

To remove the actuator, open the bayonet ring and take off the device. The device is in the middle position when delivered.

**WARNING!**

- Opening the housing creates a risk of injury.
- ▶ Do not open the housing of the actuator.

**NOTICE!**

- ▶ Disconnect the device from the power supply before removing the sealing plugs at the terminals.
- ▶ To ensure IP54 protection, seal open or unused terminals with (new) sealing plugs (see accessory 05393601000).
- ▶ Do not operate the device with open cable connections.
- ▶ Condensate, dripping water, etc. must be prevented from entering the actuator along the carrier stem.
- ▶ Only use approved SAUTER cables with suitable plugs, see PDS 53.950.

Factory setting

A standard program is loaded in the factory setting that ensures operation in standard mode. At T-01, the actuator can be given the control voltage $y = 0 \dots 10 \text{ V}$. At T-02, the feedback signal $y_0 = 0 \dots 10 \text{ V}$ is output. The range of the control voltage is mapped to the adapted angle of rotation in $0 \dots 100\%$. If the signal $y_0 = 0 \dots 10 \text{ V}$ is interrupted and if the interpretation of the control signal is set to "cw" (clockwise), the ball valve is closed completely (0% position).

The angle of rotation range can be limited via a min/max value. The control signal and the feedback signal can be read out via BACnet objects. Bluetooth LE is activated. No password is set for access to the actuator.

**Restart with factory setting**

1. Disconnect 24 V power supply.
2. Switch on 24 V power supply and press and hold Bluetooth button for at least 3 seconds. The operating and Bluetooth LEDs flash simultaneously for 5 seconds.

The Smart Actuator restarts with the factory settings.

Adaptation and feedback signal

After fitting the actuator on the ball valve, the angle of rotation must be adapted. This adaptation can be started manually, via the mobile app or via BACnet. During adaptation, the actuator must be connected to the power supply.

Manual adaptation



Press the manual adjustment button twice within 4 seconds.

After the adaptation starts, the green LED flashes and the actuator moves to the first stop. Then it moves to the second stop. The range is recorded and stored by the electromechanical travel measurement system. The control signal and the feedback of the internal DRIVE module are adapted to this effective travel and set to 0...100%.

This new adaptation is valid when the whole process is complete. If the manual adjustment button is pressed again during the adaptation, the process is interrupted and the previous state is displayed again.

After a power failure, a new adaptation is not performed as the actuator detects its current position via the travel measuring system. The adaptation values remain stored.

The status of the adaptation ("not adapted", "adaptation running", "adapted" and "error"), as well as the currently measured angle of rotation in degrees, can be read out via BACnet.

After motor parameters are changed, the actuator must be adapted again. This is indicated by a "not adapted" status for the adaptation. In the unadapted state, the Smart Actuator always starts at 50% until a stop is reached.

The adapted angle of rotation range can be adapted to different applications by means of limitations. On the one hand, the minimum and maximum positions can be configured as percentages and the maximum range can be set in degrees for one-sided adaptation.

The "jammed" state is indicated at the error output in the rotation angle range of 10...90%. If the "RetryAct" parameter is set to "On", the actuator attempts to overcome the jamming independently by repeated movement. If the jamming can be overcome, the normal control function is activated again. The feedback signal is present again and the error message is deleted.

DRIVE module

Function

Regardless of the application used, a DRIVE object is used to control the actuator. This BACnet Loop object provides all the parameters required for the actuator configuration and is present once per Smart Actuator. The parameters can be configured via CASE Engine or via the mobile app.

Description

The actuator target position (control signal) in the range of 0...100% of the adapted angle of rotation is specified to the DRIVE module as X or X_Ref. Depending on the set parameters, the internal positioner controls the motor in such a way that the actual position matches the target position within the set parameters for dead zone and hysteresis.

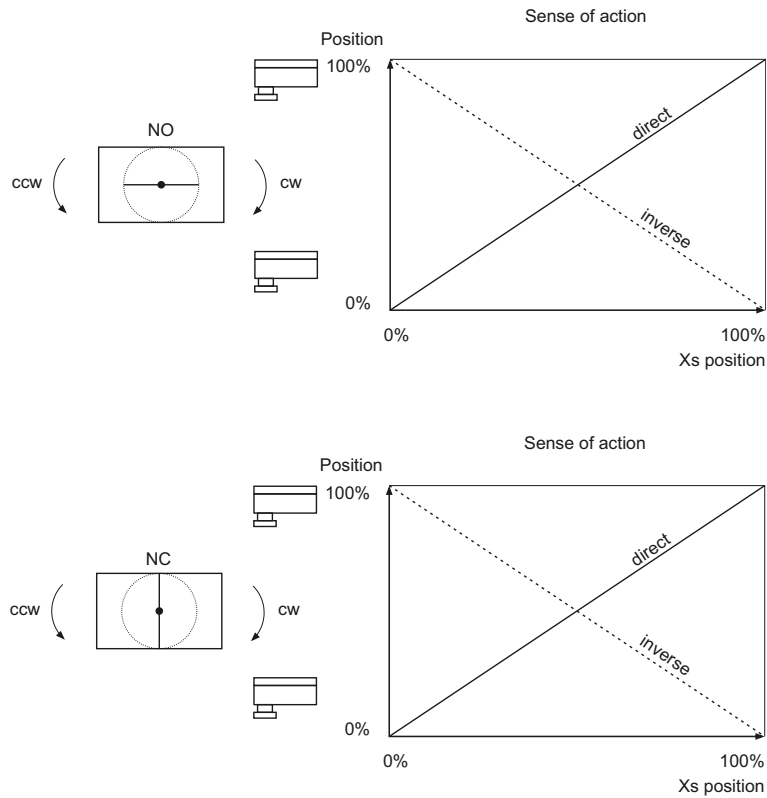

– Block definitions –

Instance number

The instance number is used to address this object and must be unique within the device for the corresponding module type. The BACnet Property Object Identifier results from the combination of the BACnet Property Object Type (Object_Type, 12) and the instance number. The Object Identifier is used to identify the BACnet object. The composite Object Identifier must be unique within the BACnet device.

Object name

The object name (Object_Name) is mandatory and must be unique within the BACnet device. It is used to address data points easily and quickly.

The object name should uniquely identify a data point within the entire project. Digression: In multi-vendor systems, the same object name can exist in different BACnet devices as BACnet requires it to be unique only within the device.

For easy logical assignment, the object name should have a unique structure with a meaningful mnemonic code. Depending on the project specification, it may be composed of identifiers for location, system and building automation. For MSTP networks, up to 32 characters can be used.

The following structure is recommended:

	Network no.	DOI	Object type (short)	Instance no.	Description
Number of characters	1	/ 3	_ 2	_ 3	_ 19

The object name can be assigned in CASE Engine.

Description

The description makes it easier to identify function and objects, e.g.: AKM115SA ball valve actuator. This text appears in the CASE Engine application plan under the function module.

– Structure definitions –

Name	Description
FreeChar	Free actuator characteristic
	After the structure definition is activated, a freely definable actuator characteristic can be configured in the parameter range. For this purpose, 10 reference points are available within an X-Y coordinate cross. X-values refer to the signal input, Y-values to the signal output. The characteristic can only be selected via the mobile app, but not changed.

Connections

On this tab, input and output connections of the DRIVE module can be activated or deactivated in the CASE Engine application plan.

Inputs

Name	Data type	Values	Description
X	Float32	0...100 (0)%	Control signal in percent related to the adapted angle of rotation
X_Ref	–	–	Control signal as Controlled Variable Reference to the object containing the current value of the system. This is a BACnet property (Controlled_Variable_Reference, 19) and its value is available in the BACnet property (Controlled_Variable_Value, 21). The signal is used for connection with a LOOP object
OvrMode	U32 (MS)	1 = Auto (1) 2 = 100% 3 = Stop 4 = 0% 5 = Position x%	Priority control that overwrites the control signal X or X_Ref when active
OvrPos	Float32	0...100	Position in percent for override; becomes active when Ovr-Mode = 5
AdptTrig	Bit	0.1 (0) ⁶⁾	Starts the angle of rotation adaptation of the actuator
LEDDsbl	Bit	0 = false (0) 1 = true	Deactivates the LED indicators on the actuator and the I/O module

Outputs

Name	Data type	Values	Description
PV	Float32	0...100 (0)%	Position feedback in percent related to the adapted angle of rotation
DriveSt	U32 (MS)	1 = Stop 2 = Running 3 = Jammed 4 = Disengaged	Current operating status of the motor
AdptSt	U32 (MS)	1 = Not adapted 2 = Running 3 = Adapted 4 = Error	Status of the angle of rotation adaptation
Err	U32 (MS)	1 = No error 2 = Undervoltage 3 = Actuator jammed 4 = Max. torque reached 5 = Max. temperature reached 6 = Sensor error (position feedback) 7 = Max. power failures exceeded 8 = Maintenance fingerprint 9 = Program error	If an internal error occurs, a corresponding error code is output

⁶⁾ After triggering the adaptation, the input must be reset to 0. If this is not done, the adaptation restarts after each power failure

Name	Data type	Values	Description
AdptRng	Float32	0...100°	Angle of rotation determined during adaptation. If the actuator is not adapted, the angle of rotation is output as 0
StFlgs	Bit	0.1 (0)	This BACnet property (Status_Flags, 111) represents the status of the BACnet object according to four criteria [IN_ALARM, FAULT, OVERRIDDEN, OUT_OF_SERVICE]. A bit value of 1 means that the corresponding flag is set. The connection of this output is not active and is available for monitoring purposes only (online view)
EvSt	Data type	Values	This BACnet property (Event_State, 36) indicates whether an active event is associated with this object. The connection of this output is not active and is available for monitoring purposes only (online view). Range: NORMAL = 0, FAULT, OFFNORMAL, HIGH_LIMIT, LOW_LIMIT, LIFE_SAFETY_ALARM

Parameters

On this tab the parameters of the function module are listed. The parameters are loaded into the station if the function "Keep parameters of the DRIVE module in the AS" is not activated during the plan download.

Parameter	Default	Value range	Function
DrvAct	cw	cw / ccw	Actuator rotates clockwise (cw = clockwise) Actuator rotates anti-clockwise (ccw = counter-clockwise)
SenseAction	Direct	Direct / indirect	Interpretation of the control signal Direct = increasing control signal Indirect = falling control signal
Runtime	120 sec.	35 / 60 / 120 sec.	Nominal runtime of the actuator in seconds
ErrPos	NO	NO / NC	Error position: Defines the default position in case of error NO = normally open NC = normally closed
Char	Linear	<ul style="list-style-type: none"> • Linear • Equal-percentage • Quadratic • Inverse equal-percentage • Inverse quadratic • Free curve 	Characteristic: Defines the characteristic of the actuator. A freely defined curve with 10 reference points can be configured via CASE Engine
MinPos	0%	0...100%	Minimum position: Defines the lower position limit in the adapted range in percent
MaxPos	100%	0...100%	Maximum position: Defines the upper position limit in the adapted range in percent
StrtDly	5 sec.	0...1200 sec.	Start delay: The start delay specifies the time in seconds that the actuator waits to restart after a power failure
ClvBlocProt	Off	Off / 1 week / 1 month	Valve jamming protection: If activated, the actuator measures the time without movement. After a set time, the actuator moves over a quarter of its set travel path and back to avoid valve calcification
DrvOptPos	Off	Off / On	Actuator position optimisation: When activated, the actuator always moves to the setpoint from one direction
DrvHys	0.5%	0.2...5%	Actuator hysteresis: Setting of the hysteresis in percent within which the actuator does not move when the setpoint changes direction
DZ	0.5%	0.2...5%	Dead zone: Setting of the dead zone with respect to the minimum signal change without changing the direction of travel
RetryAct	No	No / Yes	In the activated state, if a blockage is detected, the actuator attempts to overcome it by moving to the position multiple times. It retries after 5, 30, 60, 120 and 240 seconds. If the blockage cannot be overcome, the actuator switches to the error state "Actuator jammed"
AdptLeft	Yes	Yes / No	Adaptation is performed only on one side (left)
AdptRight	Yes	Yes / No	Adaptation is performed only on one side (right)

Parameter	Default	Value range	Function
MaxRange	0	–	Limitation of the range for one-sided adaptation
InvertPV	No	No / Yes	The feedback signal is inverted

Behaviour in the event of a power failure

The user program and the parameterisation are permanently saved in the Smart Actuator in a flash module and are retained even if there is a power failure. A buffer capacitor in the device ensures that the Real Time Clock is retained for up to three days in the event of a power failure. After the power supply returns, the Smart Actuator starts with the last saved configuration. The motor is not enabled until the set time for the start delay has elapsed.

Notice



High storage or transport temperatures can greatly reduce the capacity of the buffer capacitor for the Real Time Clock.

Network and communication

The Smart Actuator has two RS-485 interfaces: RS-485 A and RS-485 B.

RS-485 A – BACnet MS/TP

The RS-485 A interface allows integration into BACnet MS/TP networks. Network configuration and addressing is performed via CASE Sun, mobile app or the SAUTER Cloud.

Factory setting



- Network speed: 38.4 kbit/s
- DOI: 1
- MAC address: 1
- EoL: Off
- BIAS: Off

If the Smart Actuator is used as the first or last device in the network, the end-of-line terminator must be activated via CASE Sun or the mobile app.

RS-485 B – SLC

The RS-485 B interface is used to connect a maximum of two SAIO 100 I/O modules and one ecoUnit3**/ecosCom581 room operating unit. Network addressing of the SAIO 100 I/O modules is done via DIP switches on the device. The network addressing of the ecoUnit3**/ecosCom581 devices is described in the respective product data sheets.

The following device combinations are possible:

Combination	Smart Actuator	SAIO 100 I/O module (1)		SAIO 100 I/O module (2)		ecoUnit3**/ecosCom581	
	EoL ⁷⁾ (SW switch, On = active)	MAC address	EoL (DIP switch)	MAC address	EoL (DIP switch)	MAC address	EoL (120 Ω at D+/D-)
1	On	1	On	–	–	–	–
2	On	1	Off	–	–	1	Yes
3	On	1	Off	2	On	–	–
4	On	1	Off	2	Off	1	Yes
5	On	–	–	–	–	1	Yes

⁷⁾ EoL: End of line resistor

Network wiring

Ready-to-plug-in cables are available for the communication wiring between two Smart Actuators as well as between Smart Actuator and BACnet router or Smart Actuator and SLC devices.

The wiring must be separated from the other power-carrying wiring and must adhere to the specifications of standards EN 50174-1, EN 50174-2 and EN 50174-3.

The bus length for communication (BACnet MS/TP, SLC) between two devices depends on the bus cable used. Bus terminating resistors and BIAS (PU/PD) (RS-485 A only) can be parameterised on the Smart Actuator. Activation of the bus terminating resistors is generally recommended and is particularly important for longer bus cables and/or higher baud rates. Activating the BIAS is particularly recommended if any of the participants are not fail-safe.

When connecting the bus wiring via terminals, ensure that the polarity of all signals is correct.

When using the pre-assembled bus wiring, no cable shielding is required. In this case, the cable length between two devices is limited to a maximum of 30 metres. If longer cable lengths are required, the standard cable can be extended with CAT-5 cables and J-Y(ST)Y cables. To achieve optimum immunity to interference, connect the cable shield of the entire bus cable continuously and connect it as directly as possible (maximum 8 cm) to the protective earth at one point.

When using standard cables (CAT-5 / J-Y(ST)Y), the maximum possible total bus length is 500 metres for SLC and 1000 metres for BACnet MS/TP.

In the case of RS-485 interfaces, the bus wiring must have line topology. Star, tree or branch topologies are not recommended.

If peripheral devices (BACnet router, BACnet MS/TP or ecoUnit3**/ecosCom581 on RS-485 B) that are installed at the beginning or end of the bus line do not have internal terminating resistors, a terminating resistor of 120 Ω (0.25 W) must be connected in parallel to each of the data lines D+/D-.

A maximum of 50 Smart Actuators (1/4 unit load each) is possible for BACnet MS/TP segments. However, the smallest possible segments are recommended. For reactivity on the BACnet visualisations, about 30 to 40 Smart Actuators in an MS/TP segment are practicable, so that the MS/TP can still have sufficiently fast bus communication performance.



Firmware update

For trouble-free and fast firmware updates, it is recommended that additional communication on the MS/TP network be kept to a minimum.

For master-slave room zones with fast, synchronous switching, it is recommended to limit the number of BACnet MS/TP devices to 20 to 24 per segment.

Instead of RS-485 repeaters, certified BACnet routers (e.g. from Contemporary Controls, Loytec, MBS Software) are recommended. These BACnet IP MS/TP routers with one or more ports can integrate the MS/TP segments into a BACnet/IP parent BACnet network.

When connecting the BACnet router via Ethernet to a BACnet IP network, ensure sufficient electrical isolation.

For further details, see fitting instructions P100018522 of the AKM 115SA Smart Actuator.

BACnet MS/TP network with separate power supply and electrical isolation

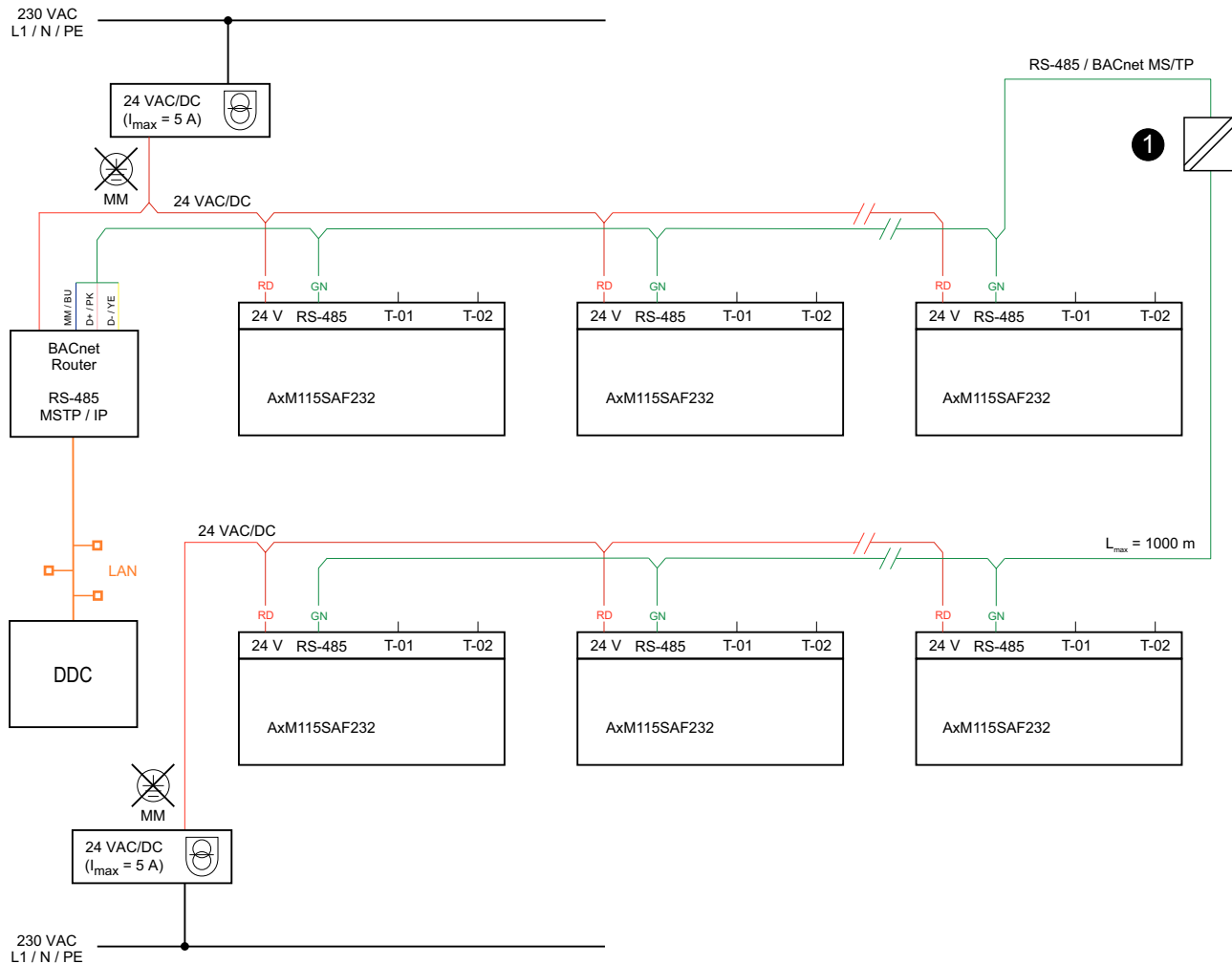

(1) Isolate network if multiple power supplies are used

BACnet MS/TP network with shared power supply

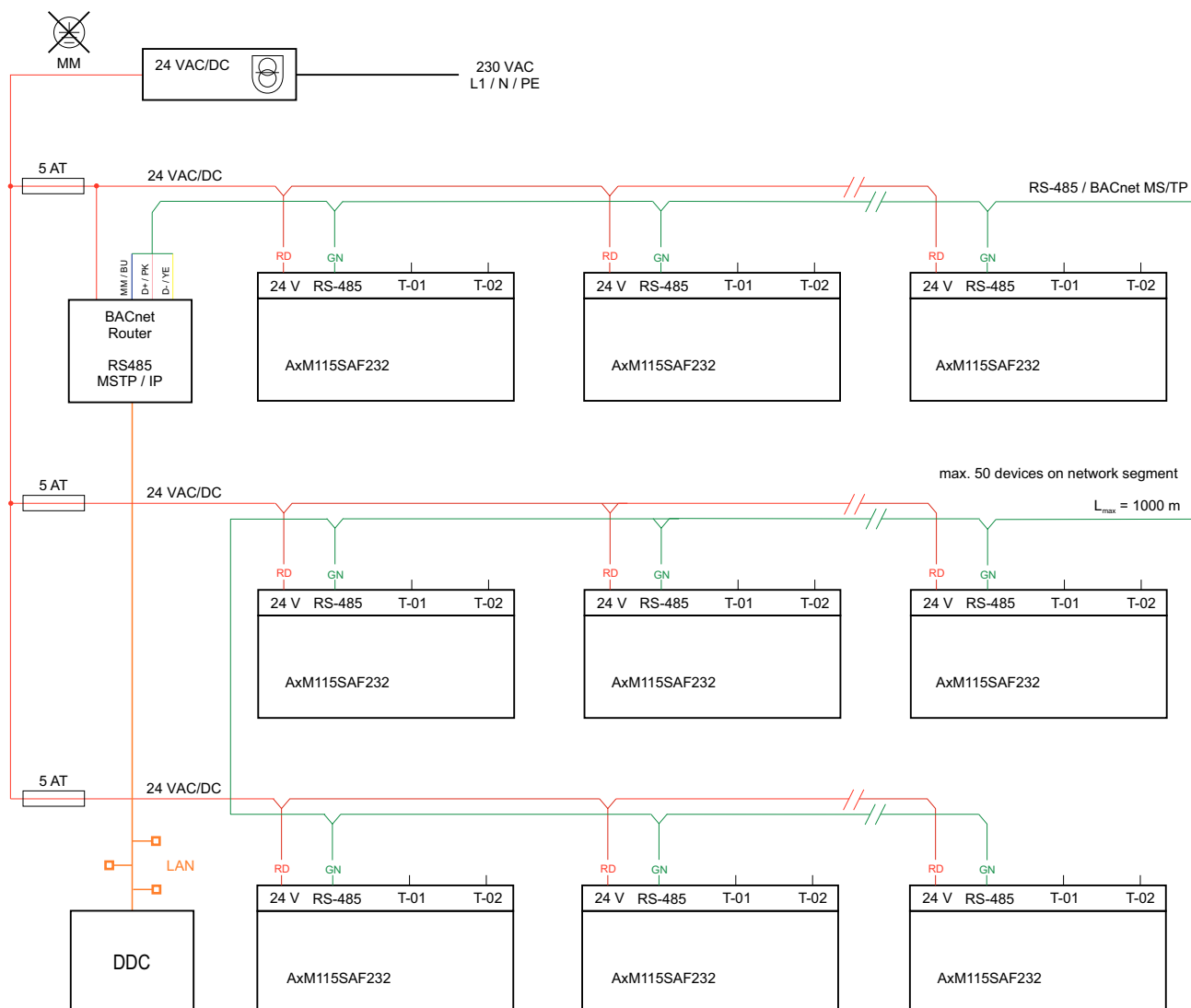

Commissioning via Bluetooth LE

The Smart Actuator can be configured via the Bluetooth interface using the SAUTER Smart Actuator app. The mobile app is available free of charge in the Google Play Store and the Apple App Store.

Pairing devices via Bluetooth



The Smart Actuator restarts with the factory settings.

1. Activate Bluetooth on the smartphone or tablet.
2. Activate Bluetooth on the Smart Actuator. To do this, press the Bluetooth button between the status LEDs for 3 seconds.
The blue status LED flashes. The device waits 3 minutes for pairing with the smartphone.
3. Scan the Q code on the device or press the "Discover devices via Bluetooth" button and select the device from the list displayed.
4. If a password is set for device security, enter the password of the Smart Actuator in the app.

The blue status LED lights up continuously. The Smart Actuator and the smartphone or tablet are paired.

Notice



The Bluetooth interface can be deactivated via CASE Sun, CASE Engine or via the SAUTER Cloud using the mobile app. Manual activation on the device by pressing a button is then no longer possible. After a power failure, the Smart Actuator and the smartphone must be paired again. A Smart Actuator can only be paired with one smartphone or tablet at a time.

SAUTER Cloud integration and mobile app

As an IoT actuator, the Smart Actuator can be connected directly to the SAUTER Cloud via the integrated WLAN interface. The interface is activated and configured via CASE Sun, CASE Engine or the mobile app. In order for the Smart Actuator to be logged on to the SAUTER Cloud, the device must be assigned to a project. Projects and associated users can be created and administered using the app.

The SAUTER Cloud makes the following functions of the Smart Actuator available for remote access via the mobile app:

- Device configuration
- Configuration of the network interfaces, e.g. enabling / disabling Bluetooth LE
- Loading and parameterising heating and air conditioning applications
- Visualisation of live values
- Backup and restore of configurations
- Creating and organising projects
- Configuration of users
- Connecting projects and devices to the SAUTER Cloud
- Firmware update via the Cloud
- Creating templates

Security

All data and system information stored in the flash memory is encrypted with 128-bit AES. To prevent unauthorised access via Bluetooth LE, it is necessary to set the device password using the mobile app. If the Smart Actuator is added to a project and is to be connected to the SAUTER Cloud, it is mandatory to assign a password.

Notice



If the device password is lost, the Smart Actuator must be reset to the factory settings and reconfigured.

The actuator supports up to three user groups:

- Administrator
- Specialist
- Guest

When using applications, detailed write and read accesses can be configured for user groups based on the parameters used.

The data transfer between Smart Actuator and SAUTER Cloud is encrypted via MQTT.

Technical specifications of the inputs and outputs

Universal inputs (UI)

The functions of the universal inputs are defined during the application creation with CASE Engine.

Number of inputs	2
Type of inputs	Voltage (U) Current (I) Ni1000/Pt1000 Resistance (R) Digital input (DI)
Protection against external voltage	30 VDC / 24 VAC
Refresh rate	100 ms (U), 600 ms (R, Ni1000, Pt1000)

Voltage measurement (U)

A 3- or 5-pin (V) cable is used for the voltage measurement. The voltage to be measured is connected between the grey (signal) and blue (MM) wires. The signal must be potential-free. If required, an offset and the slope can be set via CASE Engine.

Voltage (U)	With cable 053060510** (T-01) or 053060310** (T-02)
Measuring range	0...10 V
Resolution	≤ 0.01 V

Accuracy	± 0.05 V
Input impedance (R _i)	100 kΩ

Current measurement (I)

A current measurement 0(4)...20 mA is possible with the (I) cable 05306031105. A parallel resistor (500 Ω) between the grey wire (signal) and the blue wire (MM) is integrated in the cable on the connector side. The current signal must be potential-free and is connected between the grey and blue wires.

Current (I)	With cable 05306031105 for current measurement (T-02)
Measuring range	0(4)...20 mA



NOTICE!

Device damage due to short circuit.

- ▶ The 24 V power supply must not be short-circuited with the ground (blue wire) or the signal cable (grey wire).

Temperature measurement (Ni/Pt)

For direct temperature measurement, plug-in cable temperature sensors (T) are available in various lengths and versions (Ni1000 and Pt1000).

Standard Ni/Pt1000 sensors or resistors can still be connected using two wires by means of a 3- or 5-pin (V) cable. The signal to be measured is connected between the grey (signal) and blue (MM) wires. No external common ground point should be used for the temperature measurement.

The inputs require no calibration and can be used immediately. Long sensor lines with corresponding line resistance can be compensated in the CASE Engine application plan.

At a cable resistance of 2 Ω (cable cross-section 1.5 mm², 85 m) of an Ni1000 sensor, the function module CH_AI receives the scaling parameters Offset b = -0.435 and Scaling a = 1 (for operating point 21 °C). Other cable resistances can be calculated and can be compensated via the parameterisation in CASE Engine.

Ni1000	DIN 43760 with cable 053060320** (T-02)
Pt1000	IEC 751 with cable 053060521**
Measuring range	-20...100 °C
Resolution	≤ 0.3 K
Accuracy	± 1 K
Measurement current	≤ 1 mA

Resistance measurement (R)

A 3- or 5-pin (V) cable is used for the resistance measurement. The resistor to be measured is connected between the grey (signal) and blue (MM) wires.

The measuring range for the resistance measurement is limited to 3 kΩ. If line break detection is desired, this measurement can be recorded in the CASE Engine application plan with a threshold value of e.g. 2.9 kΩ.

Resistance (R)	With cable 053060510** (T-01) or 053060310** (T-02)
Measuring range	200...3000 Ω
Resolution	≤ 5 Ω
Accuracy	± 10 Ω
Measurement current	≤ 1 mA

Digital inputs (DI)

The digital input function can be used with both potential-free contacts and voltage signals. A 3- or 5-pin (V) cable is used to record potential-free contacts as well as voltage signals. The potential-free contact or the voltage to be measured is connected between the grey (signal) and blue (MM) wires.

Digital inputs are generally used as alarm/status inputs. Therefore, an open contact corresponds to the state 0 = Inactive (bit = 0). A closed contact corresponds to the state 1 = Active (bit = 1). This assignment, defined as normal polarity, can be inverted using CASE Engine if required.

Digital input (DI)	With cable 053060510** (T-01) or 053060310** (T-02)
Potential-free contacts	Connected to ground Closed (1): < 2 kΩ Open (0): > 3 kΩ
Output current	≤ 1 mA
Voltage signal	Switching threshold low (1): ≤ 1 V Switching threshold high (0): ≥ 4 V

Analogue outputs (AO)

A 3- or 5-pin (V) cable is used to record the output voltage. The 0...10 V signal is applied between the grey (signal) and blue (MM) wires.

The output can be subjected to a load of 1.5 mA up to 10.5 V (the outputs do not have an active sink capability).

The analogue output is short circuit-proof and grounded and is protected from external voltage.

NOTICE!



Device damage due to short circuit.

► Permanent short-circuiting of multiple outputs leads to their thermal destruction.

► A short circuit of the analogue outputs can lead to undesired I/O states.

LED indicator

Two LEDs in the cover of the Smart Actuator indicate its operating statuses.

The 3-colour, left LED (the electrical connections are located to the left of the observer) is used to signal general states of the device. The blue, right LED signals the status of the Bluetooth LE interface.



Left LED (3-colour)

Status ⁸⁾	Indicator/display	Description
Off		Device off, no power supply
Continuous green		Normal mode
Green→Orange→Red		Device being localised
Rapidly flashing green		Adaptation running
Continuous orange		Device is starting
Flashing orange		Firmware update
Continuous red		Configuration incorrect, program missing or program download
Rapidly flashing red		Firmware error
Orange (left LED) and blue (right LED) alternately flashing		Factory setting being loaded

⁸⁾ LED flashing: 500 ms on, 500 ms off

LED flashing rapidly: 100 ms on, 100 ms off

Right LED (blue)

Status ⁹⁾	Indicator/display	Description
Off		Bluetooth deactivated
Blue flashing		Bluetooth on, not connected
Continuous blue		Bluetooth connection to mobile app active

BACnet and DDC function with CASE Suite

The Smart Actuator is a BACnet MS/TP device as per BACnet device profile B-ASC (BACnet Application Specific Controller) with the additional support of BACnet time programme objects (Schedule / Calendar).

The Smart Actuator is freely programmable with function blocks and SAUTER CASE Suite. The program is downloaded to the device via a BACnet router with CASE Engine.

The switch-on phase of the Smart Actuator is approximately 4 seconds. The device has a plan cycle time of 100 ms. Relevant process data, e.g. setpoint as Present Value of an AV object, can be parameterised so that it is saved persistently. A firmware update can be performed with CASE Sun via BACnet router or via the mobile app and the SAUTER Cloud.

NOTICE!

Data loss due to incorrect firmware update

► Always back up the user data or system configuration before updating the firmware.

Notice

For trouble-free and fast firmware updates, it is recommended that additional communication on the MS/TP network be kept to a minimum.

The user parameters from CASE Engine and the user data (e.g. modified by BACnet client) are permanently stored in the flash memory and are power-independent.

The following function limits apply:

Function, BACnet object	Quantity
BACnet Value objects (analogue, binary, multi-state)	50
BACnet Loop objects	6
BACnet Schedule objects	4
BACnet Calendar objects	3
BACnet Client (DS-RP-A/DS-COV-A with EXT_VAL function block)	
Optimisation modules (OPT_H + OPT_C)	4
Group communication modules (GRPCOM_B)	32
Group communication modules (GRPCOM_R + GRPCOM_U)	12
Room operating unit module (ROOM_UNIT)	1
Number of SAIO 100 I/O modules	2
Number of COV logins	64
Max. number of master-slave devices in a group	8 (1 master, up to 7 slaves)
Number of function modules (without BACnet objects), total	200

Further information on BACnet and DDC functionality is available in the BACnet PICS (Protocol Implementation Conformance Statement) and the online help for CASE Suite.

Live Values

For commissioning purposes, up to three BACnet objects can be monitored simultaneously via mobile app or via the SAUTER Cloud. The maximum display duration of Live Values is 1 hour. After this, the data is updated according to the FIFO principle. The data update frequency is 2 seconds. When the Live Values page is closed in the app or in the SAUTER Cloud, the data is deleted.

⁹⁾ LED flashing: 500 ms on, 500 ms off

Integration of the inputs and outputs of the SAIO 100 I/O modules and the room operating unit with CASE Suite

The engineering of the inputs and outputs of the Smart Actuator and the SAIO 100 I/O modules is performed using CASE Suite. When a Smart Actuator is selected in the BACnet MS/TP network plan, it can be created for one to eight master-slave rooms in an AS group.

The types and addresses of the required SAIO 100 I/O modules (1, 2) and the room operating unit (1) are specified in the Definition module within CASE Engine. Subsequently, all inputs and outputs of the Smart Actuator (T-01, T-02), the SAIO 100 I/O modules (T-03 to T-06 and BO-10 to BO-12) and the room operating unit can be used in CASE Engine as a channel (CH_Ax, CH_Bx) and as a ROOM_UNIT, and mapped to BACnet data points (Value Objects).

RTC (Real Time Clock)

A Real Time Clock (RTC) is integrated into the Smart Actuator for the time programmes (schedules / calendars). The date, time and time zone are set in the device when loading the user data. The BACnet services "DM-TS-B" and "DM-UTC-B" are used to synchronise the time and date automatically if a BACnet time master is specified accordingly (e.g. SAUTER Vision Center, moduWeb Vision, modu525). When connected via a WLAN network, the time is set by default via an NTP time server.

A manual setting of time, date and time zone can be done via BACnet browser, mobile app or CASE Sun.

Daylight saving is activated by default in the network properties (CASE Engine) of the Smart Actuator and includes all Smart Actuators and/or automation stations integrated in the same network. The deviation of the time without resynchronisation is max. 2 minutes per year.

Firmware

The Smart Actuator is supplied with up-to-date firmware. At the time of commissioning, a newer firmware version may be available. Before commissioning the system, you should therefore check whether a new version is available.

A firmware update can be performed via the BACnet MS/TP network with CASE Sun or via the mobile app and SAUTER Cloud. After connecting to the SAUTER Cloud, as soon as new firmware is available, the new firmware is offered for installation in the "Overview" area of the mobile app.

Additional technical documents

Fitting instructions	P100018522
Declaration on materials and the environment	D100465216

Disposal

When disposing of the product, observe the currently applicable local laws.

More information on materials can be found in the Declaration on materials and the environment for this product.

Connection diagram

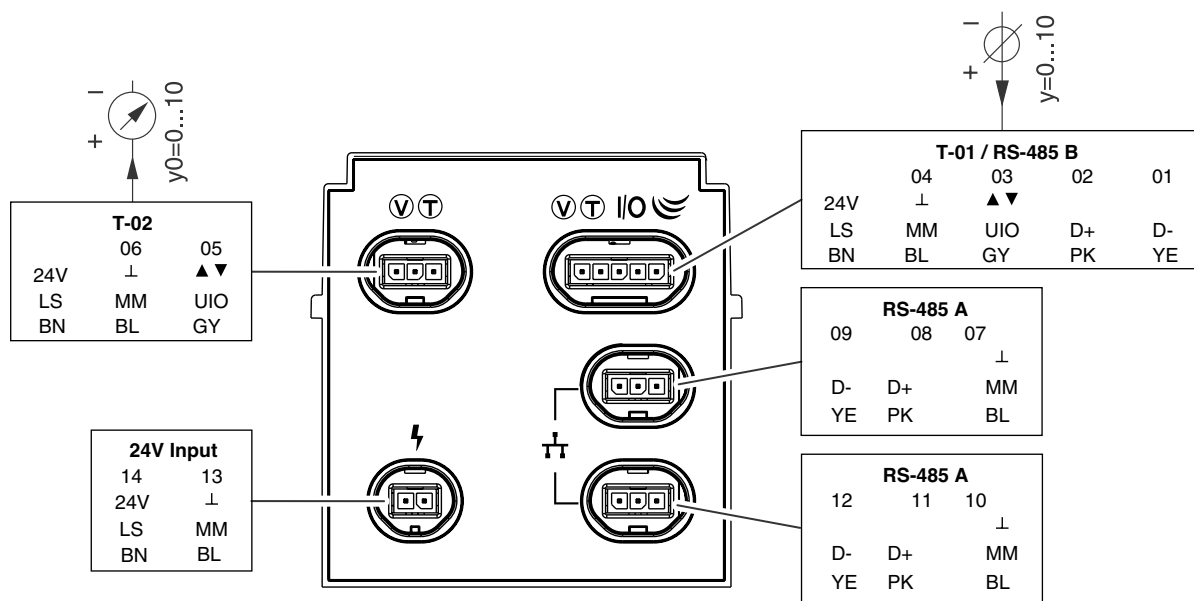
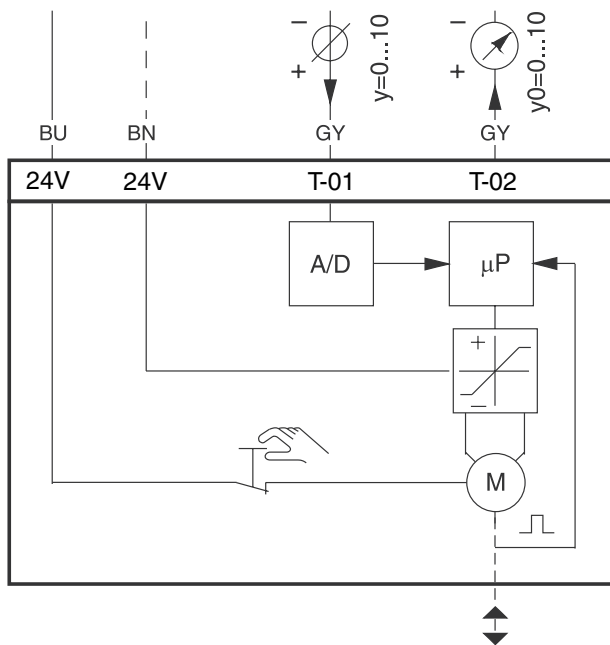

Dimension drawing

All dimensions in mm.

