

de Elektrischer Drehantrieb
 fr Servomoteur électrique rotatif
 en Electric rotary actuator
 it Servomotore radiale elettrico
 es Actuador rotativo eléctrico
 sv Elektriskt roterande ställdon
 nl Elektrische Rotatieaandrijving

de Montagevorschrift
 fr Instruction de montage
 en Fitting instructions
 it Istruzioni di montaggio
 es Instrucciones de montaje
 sv Monteringsanvisning
 nl Montagevoorschrift

ASM105F122U
 ASM115F122U
 ASM105SF132U
 ASM115SF132U
 ASM105SF152U

de Installationsanweisung für die Fachkraft / Monteur
 fr Conseils d'installation pour le spécialiste / monteur
 en Guidelines for the technician / fitter
 it Informazioni per il personale specializzato di montaggio
 es Instrucciones para el especialista del ramo / montador
 sv Installationsinstruktion för installatör / montör
 nl Installatietip voor de vakman / monteur

de Für den Einsatz in üblicher Umgebung, 3K3 nach IEC 60721.
 Verschmutzungsgrad II, Stossspannungsfestigkeit 800 V,
 nach UL/EN 60730.
 fr Pour usage dans un environnement normal, 3K3 selon
 IEC 60721.
 Degré de pollution II, Résistance aux surtensions transitoires
 800 V selon UL/EN 60730.
 en For use in normal environments, 3K3 as per IEC 60721.
 Pollution degree II, rated impulse voltage 800 V, as per
 UL/EN 60730.
 it Per impiego in ambiente usuale, 3K3 a norme IEC 60721.
 Grado di insudiciamento II, Resistenza alla tensione a impulso
 800 V, a norme UL/EN 60730.
 es Para el uso en ambiente normal, 3K3 según IEC 60721.
 Grado de suciedad II, Resistencia a sobretensión 800 V,
 según UL/EN 60730.
 sv För användning i normal miljö, 3K3 enligt IEC 60721.
 Grad av nedsmutsningsgrad II, Stötspänningshållfasthet 800 V,
 enligt UL/EN 60730.
 nl Voor toepassing in normale omgeving, 3K3 volgens IEC 60721.
 Vervuilinggraad II, Impulsspanningsbestendigheid 800 V,
 volgens UL/EN 60730.

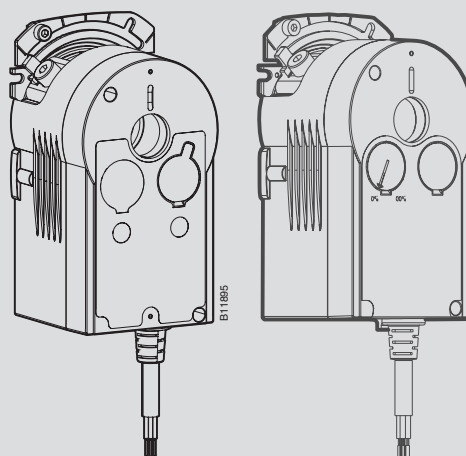

90°

ASM105: 5 Nm
 ASM115: 10 Nm
 ASM105SF152U: 3 Nm

de Temperatur der Kugeldruckprüfung: 125° C
 fr Température d'essai à la bille: 125° C
 en Temperature of the ball pressure test: 125° C
 it Temperatura del test di pressione a sfera: 125° C
 es Temperatura del ensayo de dureza Brinell: 125° C
 sv Temperatur kultrycksprovning: 125° C
 nl Temperatuur van de kogeldruktest: 125° C

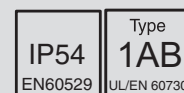

⚠ WARNING

Einsatz bei defektem Kabel verboten.
 Die nicht abnehmbare Anschlussleitung des Gerätes kann nur durch
 den Hersteller oder sein Servicepersonal ersetzt werden.
 Die nicht abnehmbare Anschlussleitung des Gerätes darf nicht
 zwischen zwei Räume verlegt werden.
 Das Gerät darf nicht in Zuluft- oder Abluftzwischenräume eingebaut
 werden.

⚠ AVERTISSEMENT

Usage interdit avec câble défectueux.
 Seul le fabricant ou le personnel de service après-vente est habilité à
 remplacer la ligne de raccordement inamovible de l'appareil.
 Toute pose de la ligne de raccordement inamovible de l'appareil entre
 deux pièces est interdite.
 Ne pas installer l'appareil dans des gaines d'air ou dans des zones
 plénum.

⚠ WARNING

Do not use if the cable is defective.
 The device's non-removable power cable should be replaced only by
 the manufacturer or the manufacturer's service staff.
 The device's non-removable power cable should not be laid between
 two rooms.
 This device is not suitable for plenum application.

⚠ AVVERTENZA

Impiego vietato nel caso di cavo danneggiato.
 Il cavo di collegamento non estraibile dell'apparecchio può essere

sostituito esclusivamente dal costruttore o dal rispettivo personale di
 assistenza. Il cavo di collegamento non estraibile dell'apparecchio
 non deve essere posato fra due ambienti.
 L'apparecchio non deve essere installato in spazi intermedi di
 aerazione o sfiatione.

⚠ ADVERTENCIA

Está prohibido el uso con un cable defectuoso.
 El cable de conexión no extraíble del dispositivo solo puede ser
 reemplazado por el fabricante o por el personal de mantenimiento.
 Queda prohibido tender entre dos salas el cable de conexión no
 extraíble del dispositivo.
 Este dispositivo no es adecuado para montaje en plenum.

⚠ VARNING

Förbjuden att använda vid skadad kabel.
 Endast tillverkaren eller dennes servicepersonal kan byta produktens
 icke-avtagbara anslutningsledning.
 Produktens icke-avtagbara anslutningsledning får ej läggas ut mellan
 två rum.
 Produkten får inte monteras i tillufts- eller frånluftsutrymmen.

⚠ WAARSCHUWING

Gebruik bij defecte kabel verboden.
 De niet-afneembare aansluitkabel van het apparaat kan alleen door
 de fabrikant of zijn servicepersoneel worden vervangen.
 De niet-afneembare aansluitkabel van het apparaat mag niet tussen
 twee ruimtes worden geïnstalleerd.
 Het apparaat mag niet in tussenruimtes voor afvoer- en toevoerlucht
 worden gemonteerd.

1

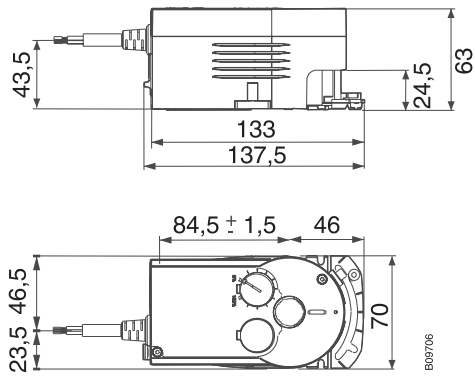

2

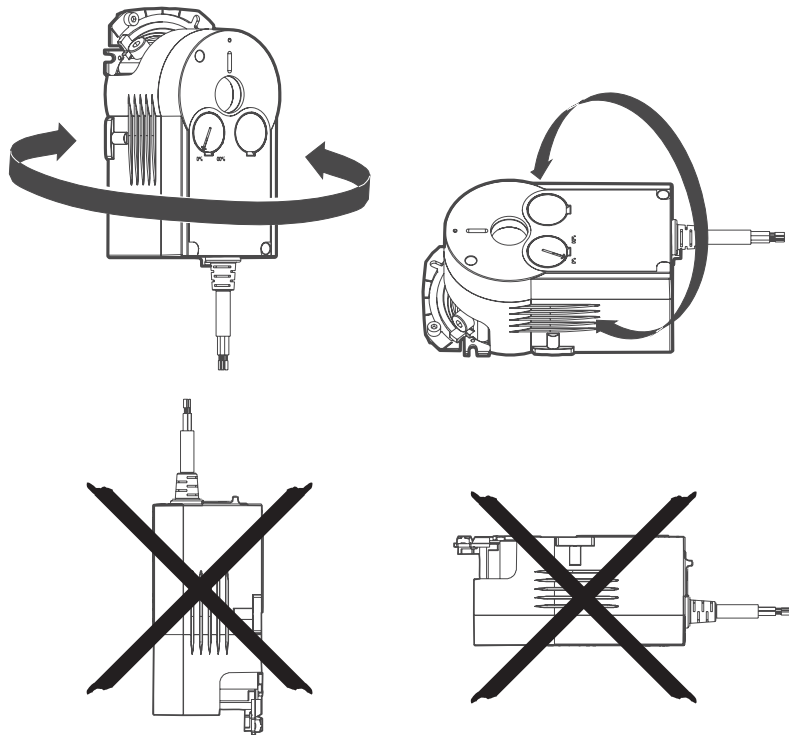

3

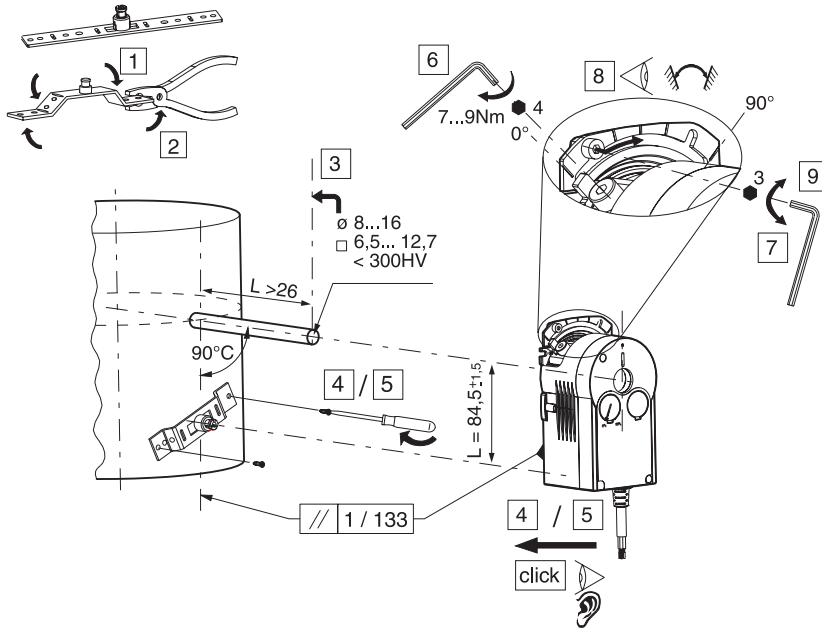

i

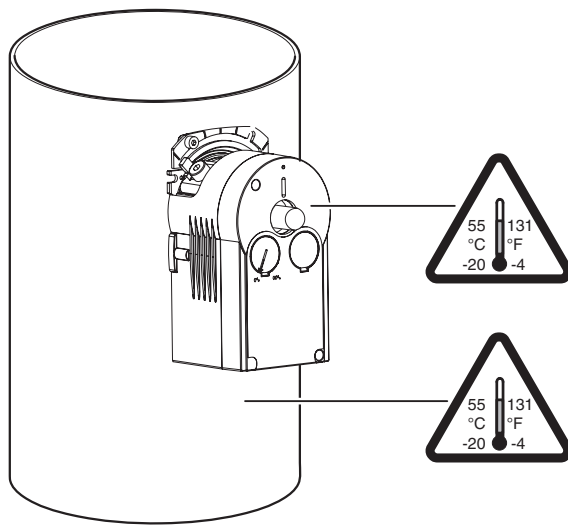

4a

ASM1x5F122U

USA/CA:
Class 2 supply
Source class 2

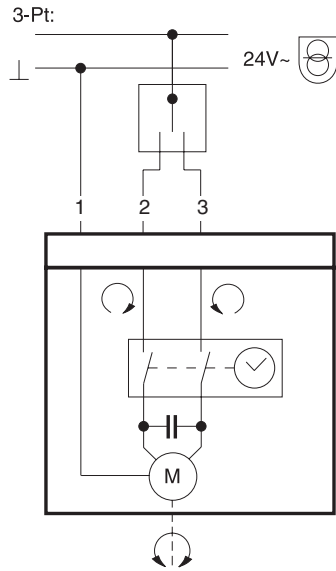

USA/CA:
Class 2 supply
Source class 2

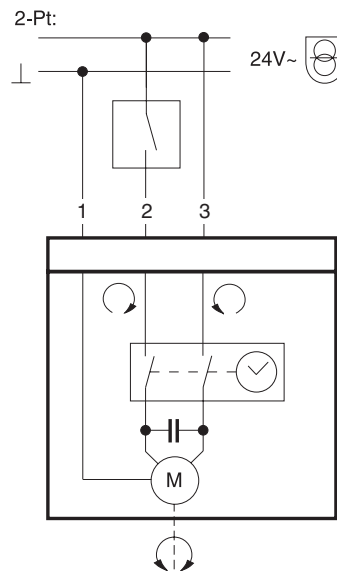

4b

ASM1x5SF132U

1

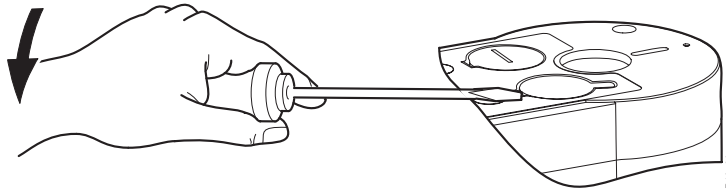

2

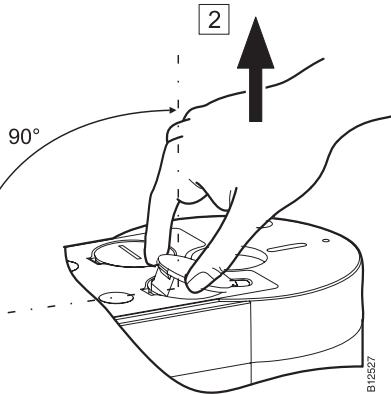

3

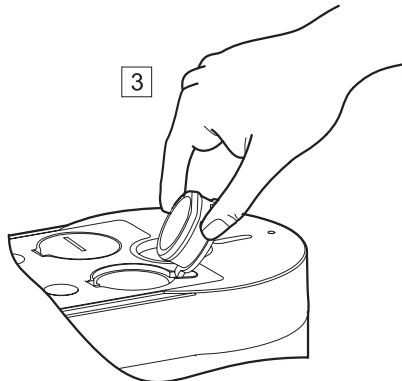

4

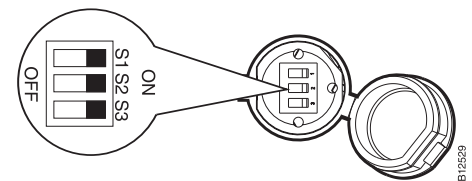

5

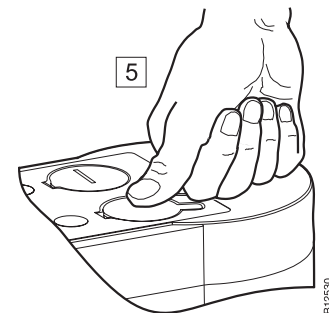

4c

ASM1x5SF132U

Software
A
UL/EN 60730

en The device is supplied by the same Class 2 source for all I/O.
fr L'appareil est alimenté par la même source de classe 2 pour toutes les E/S.
es El dispositivo se alimenta a través de la misma fuente de clase 2 para todas las E/S.

	RD	BN	BK	OG	YE
de	rot	braun	schwarz	orange	gelb
fr	rouge	brun	noir	orange	jaune
en	red	brown	black	orange	yellow
it	rosso	marrone	nero	arancione	giallo
es	rojo	marrón	negro	naranja	amarillo
sv	röd	brun	svart	orange	gul
nl	rood	bruin	zwart	oranje	geel

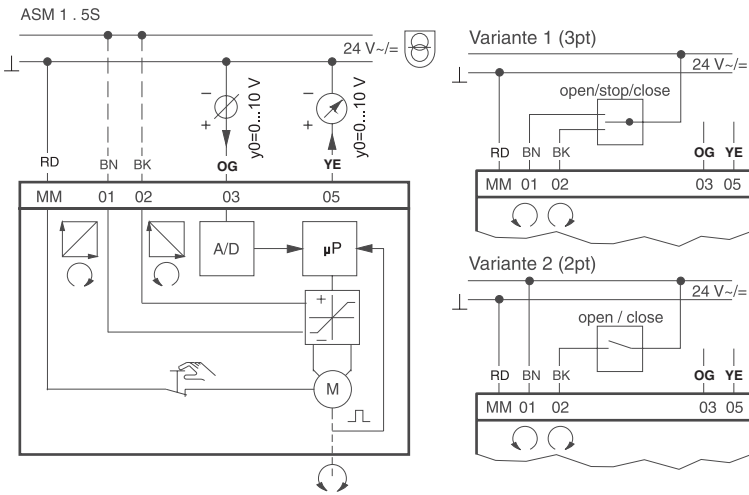

Variante 1 (3pt)

ASM 105S 90°	ASM 115S 90°	S1	S2	S3
120s	120s	off	on	-
120s	120s	on	on	-
60s	60s	on	off	-
35s	60s	off	off	-
Initialisierung ein		-	-	on
Initialisierung aus		-	-	off
		on	on	on

Variante 2 (2pt)

ASM 105S 90°	ASM 115S 90°	S1	S2	S3
120s	120s	off	on	-
120s	120s	on	on	-
60s	60s	on	off	-
35s	60s	off	off	-
Ini.		-	-	on
Ini.		-	-	off
		on	on	on

de	Initialisierung ein	Initialisierung aus
fr	initialisation marche	initialisation arrêt
en	initialization on	initialization off
it	attivazione inizializzazione	disattivazione inizializzazione
es	activar inicialización	desactivar inicialización
sv	initiering på	initiering av
nl	initialisatie in	initialisatie uit

4d

ASM105SF152U

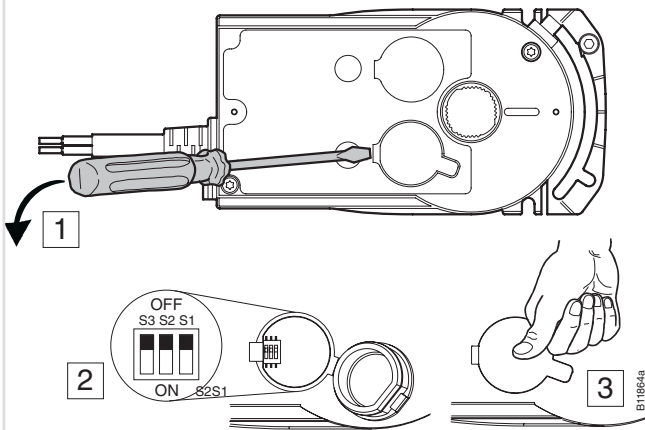

	OFF	ON
S1	normal	reverse
S2	Y: U	Y: I
S3	Y: 0...10 V = Y: 0...20 mA =	Y: 2...10 V = Y: 4...20 mA =

4e ASM105SF152U

Software
A
EN 60730

	MM RD	LS GR	01 BN	02 BK	03 OR	05 YE
de	rot	grün	braun	schwarz	orange	gelb
fr	rouge	vert	brun	noir	orange	jaune
en	red	green	brown	black	orange	yellow
it	rosso	verde	marrone	nero	arancione	giallo
es	rojo	verde	marrón	negro	naranja	amarillo
sv	röd	grön	brun	svart	apelsin	gul
nl	rood	groen	bruin	zwart	oranje	geel

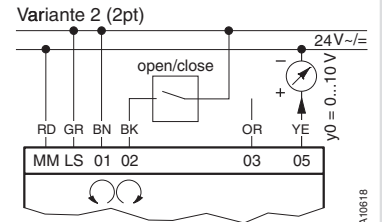
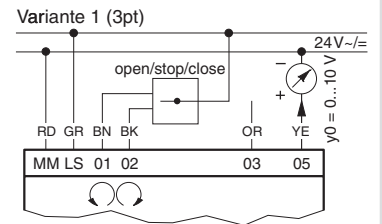
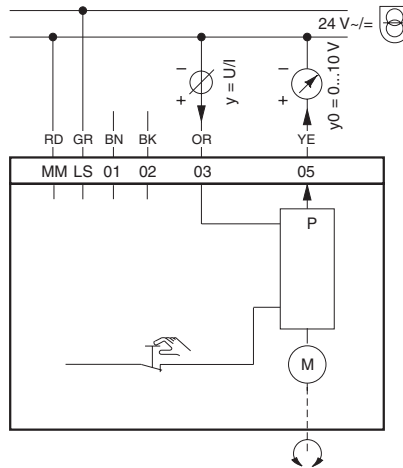

5

de **Manuell**
fr **Manuel**
en **Manual**
it **Manuale**
es **Manual**
sv **Manuell**
nl **Manueel**

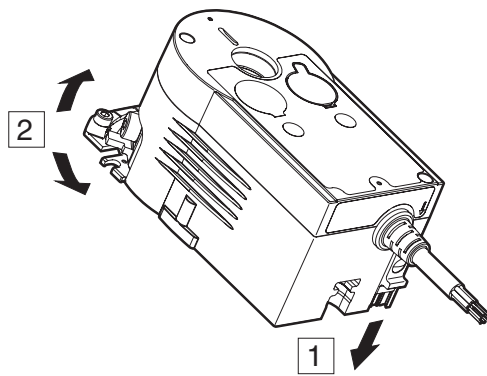

de **Warnung**
fr **Avertissement**
en **Warning**
it **Avvertenza**
sp **Advertencia**
sw **Warning**
nl **Warschuwing**



de www.sauter-controls.com ➔ Produkte ➔ MD Datenblatt.
fr www.sauter-controls.com ➔ Produits ➔ Fiche MD.
en www.sauter-controls.com ➔ Products ➔ MD Datasheet.
it www.sauter-controls.com ➔ Products ➔ MD Datasheet.
es www.sauter-controls.com ➔ Products ➔ MD Datasheet.
sv www.sauter-controls.com ➔ Products ➔ MD Datasheet.
nl www.sauter-controls.com ➔ Products ➔ MD Datasheet.

de Dokument aufbewahren
fr Ce document est à conserver
en Retain this document
it Conservare il documento
es Guardar el documento
sv Spara dokumentationen
nl Document bewaren

© SAUTER Head Office
Fr. Sauter AG
Im Surinam 55
CH-4058 Basel
Tel. +41 61 - 695 55 55
Fax +41 61 - 695 55 10
www.sauter-controls.com
info@sauter-controls.com